

**Installation an operating instruction for  
Brake DH 005 PFK**

**E 09.638e**

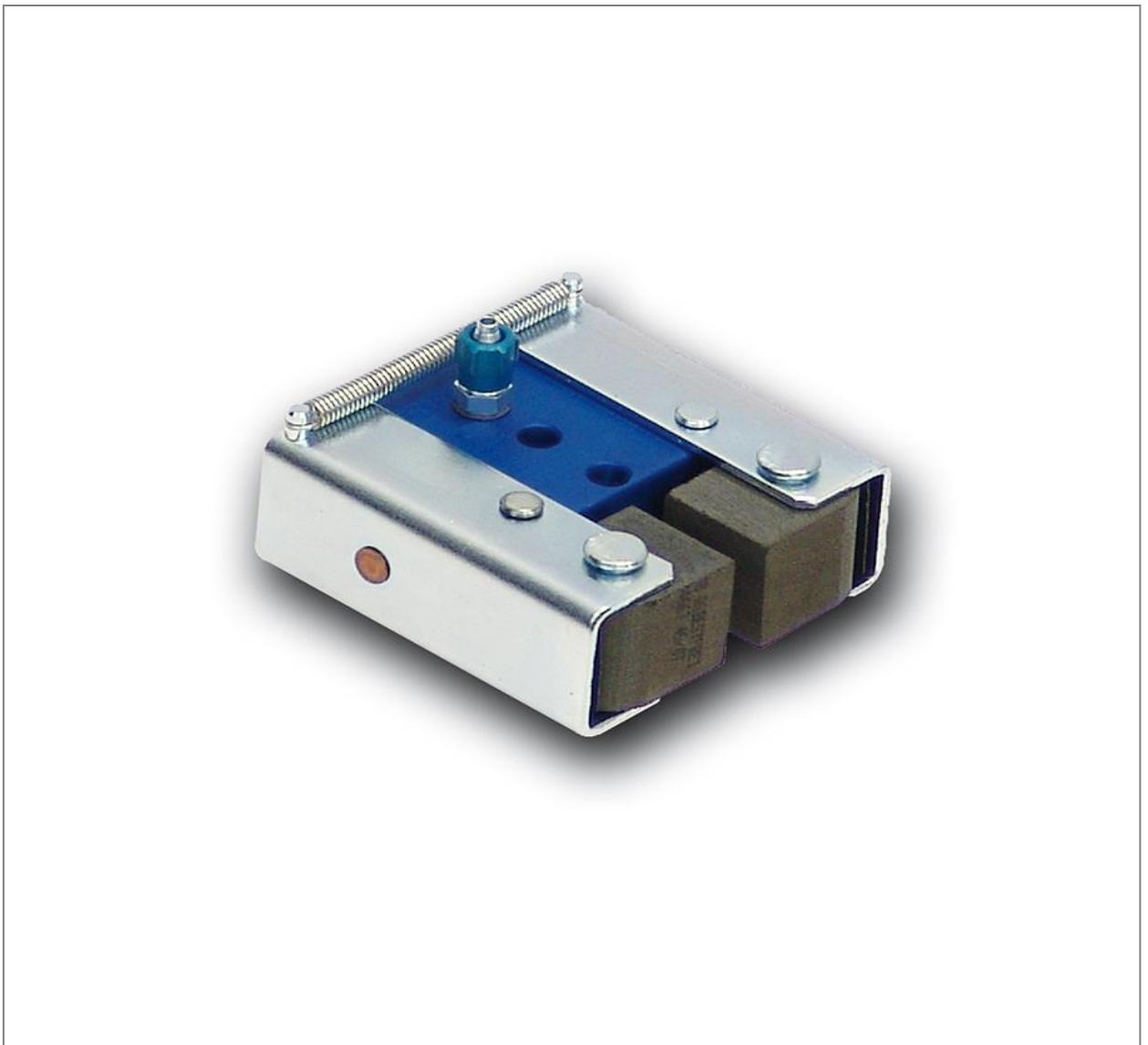

**RINGSPANN GmbH**

Schaberweg 30-38  
61348 Bad Homburg  
Germany

Telephone +49 6172 275-0  
Fax +49 6172 275-275

[www.ringspann.com](http://www.ringspann.com)  
[info@ringspann.com](mailto:info@ringspann.com)

<b>RINGSPANN</b>	<b>Installation and operating instructions for Brake DH 005 PFK pneumatically activated - spring released</b>	<b>E 09.638e</b>			
Issue: 27.07.2017	Version: 1	Signed.: BAHS	Checked: EISF	Pages: 11	Page: 2

---

## Important

Please read these instructions carefully before installing and operating the product. Your particular attention is drawn to the notes on safety.

These installation and operating instructions are valid on condition that the product meets the selection criteria for its proper use. Selection and design of the product is not the subject of these installation and operating instructions.

Disregarding or misinterpreting these installation and operating instructions invalidates any product liability or guarantee by RINGSPANN; the same applies if the product is taken apart or changed.

These installation and operating instructions should be kept in a safe place and should accompany the product if it is passed on to others -either on its own or as part of a machine- to make it accessible to the user.

---

## Safety Notice

- Installation and operation of this product should only be carried out by skilled personnel.
- Repairs may only be carried out by the manufacturer or accredited RINGSPANN agents.
- If a malfunction is indicated, the product or the machine into which it is installed, should be stopped immediately and either RINGSPANN or an accredited RINGSPANN agent should be informed.
- Switch off the power supply before commencing work on electrical components.
- Rotating machine elements must be protected by the purchaser to prevent accidental contact.
- Supplies abroad are subject to the safety laws prevailing in those countries.

### **This is a translation of the German original version!**

In case of inconsistencies between the German and English version of this installation and operating instruction, the German version shall prevail.

<b>RINGSPANN</b>	<b>Installation and operating instructions for Brake DH 005 PFK pneumatically activated - spring released</b>			<b>E 09.638e</b>	
Issue: 27.07.2017	Version: 1	Signed.: BAHS	Checked: EISF	Pages: 11	Page: 3

## Contents

### 1. General notes

- 1.1 General safety instructions
- 1.2 Special safety instructions

### 2. Design and function / parts list

- 2.1 Function
- 2.2 Identification
- 2.3 Drawing and parts list

### 3. Intended use

### 4. Impermissible use

### 5. Condition as delivered

### 6. Handling and storage

### 7. Technical prerequisite for reliable operation

### 8. Installing the RINGSPANN brake

- 8.1 General instructions regarding assembly and installation
- 8.2 Assembly description
- 8.3 Adjusting/readjusting the friction pad distance
- 8.4 Connecting the signal cable (optional)

### 9. Start-up

### 10. Disassembling the brake

### 11. Maintenance

- 11.1 General maintenance
- 11.2 Permissible friction lining wear and exchanging of the friction pad
- 11.3 Exchanging seals, wipers and piston seals

<b>RINGSPANN</b>	<b>Installation and operating instructions for Brake DH 005 PFK pneumatically activated - spring released</b>			<b>E 09.638e</b>	
Issue: 27.07.2017	Version: 1	Signed.: BAHS	Checked: EISF	Pages: 11	Page: 4

## 1. General notes

### 1.1 General safety instructions

Read these installation/operating instructions carefully before putting the brake into operation. Consider these instructions as well as the drawings in the individual sections.

All work with and on the brake is to be carried out taking into account that "safety is top priority".

Switch the drive unit off before carrying out work on the brake.

Rotating parts (e.g. brake disc) must be secured by the operator against unintentional touching.

### 1.2 Special safety instructions



#### **Life-threatening danger!**

**When assembling, operating and maintaining the brake it is to be ensured that the entire drive train is secured against being switched on unintentionally. Moving parts can cause severe injury. Rotating parts (e.g. brake disc) must be secured by the operator against unintentional touching.**

## 2. Design and function / parts list

### 2.1 Function

The brake is a machine element with which accelerated masses can be safely slowed down. In combination with a brake disc, you have a complete brake for the effective safeguarding of machines and systems. Thanks to its universal design, it fulfils the following functions:

- As a holding brake, it prevents a stationary shaft from starting unintentionally.
- As a stopping brake, it brings a rotating shaft to a halt.
- As a control brake, it maintains a particular tensile force within the material.

The braking force is produced by air pressure, and the brake is opened by springs.

### 2.2 Identification

These operating instructions apply for:

- The execution H, right-angled attachment to the machine.
- For brake disc thickness  $W = 6$
- With different friction pad variants (e.g. with cable for wear monitoring, higher sliding speed special friction materials.)
- With special frame.

<b>RINGSPANN</b>	<b>Installation and operating instructions for Brake DH 005 PFK pneumatically activated - spring released</b>	<b>E 09.638e</b>
Issue: 27.07.2017	Version: 1	Signed.: BAHS    Checked: EISF    Pages: 11    Page: 5

There is a type plate on the brake with a 16-digit article number. The exact design of the brake is defined by this article number only.

As well as these instructions, please also consider the catalogue data for the brake at [www.ringspann.com](http://www.ringspann.com) and the drawings in the individual sections.

### 2.3 Drawing and parts list

Drawing of brake DH 005

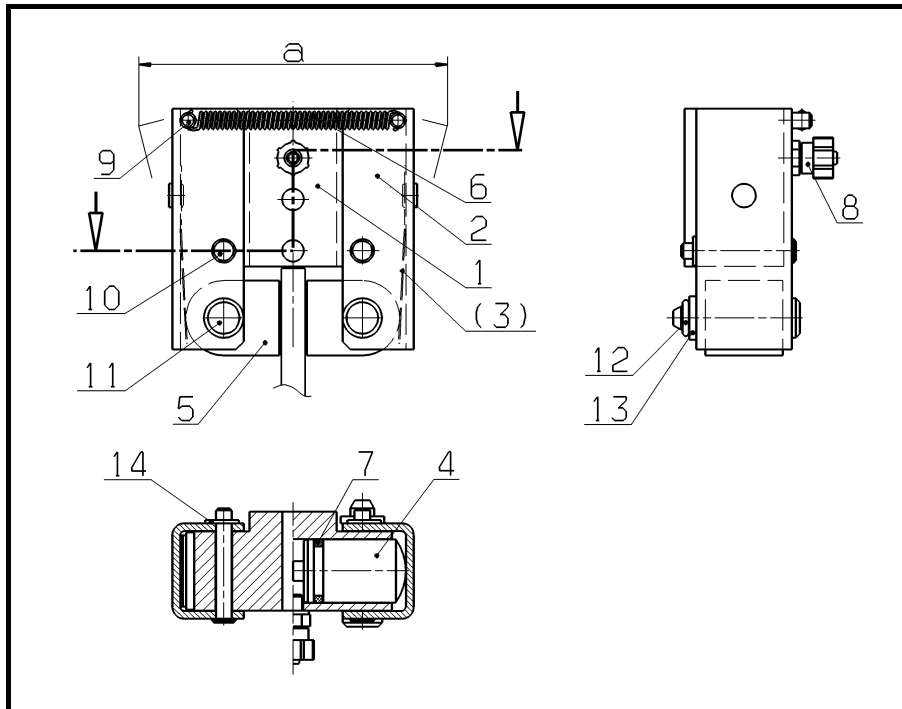

Fig. 2.1

<b>RINGSPANN</b>	<b>Installation and operating instructions for Brake DH 005 PFK pneumatically activated - spring released</b>			<b>E 09.638e</b>	
	Issue: 27.07.2017	Version: 1	Signed.: BAHS	Checked: EISF	Pages: 11   Page: 6

Part	Designation	Pc	Item number
1	Cylinder block for DH 005 PFK	1	2768.050.001.000000
2	Lever with leaf spring (part 3) for DH 005 PFK	2	2789.061.001.000000
4	Piston for DH 005 PFK	2	2712.016.618.000000
5	Standard friction block with splint for DH 005 PFK	2	3457.901.102.000000*
6	Tension spring galvanised	1	2701.004.026.000000
7	Piston seal O-ring 12x2	2	5116.012.006.000000
8	Quick coupling piece CK-M5-PK-3	1	5099.005.001.000000
9	Rivet spring bolt for DH 005 PFK	2	2725.004.605.000000
10	Bolt with head A-4x28-St	2	5213.004.150.000000
11	Bolt with head B-6x30-St	2	5213.010.151.000000
12	Splint 1.6x12	2	5202.016.106.000000
13	Disc 6.4 DIN 125-St	2	5105.006.001.000000
14	Gripping ring G 4x0.8	2	5146.004.001.000000

\* For the clear assignment of identical item no., the material number of the brake is required.

### 3. Intended use

The brake has been designed for use as a holding, control and stopping brake. Use for any other purpose will be deemed improper.

### 4. Impermissible use

It is not permissible to operate the brake with a higher pressure than prescribed in the technical catalogue data or with other media. The application of compressed air must be carried out using air that is freed from dirt, pipe sinter, rust and condensation by a filter. Unauthorised constructional changes to the brake are also not allowed.

### 5. Condition as delivered

The brake is tested prior to delivery. The brake is delivered ready to install. The brake is delivered depressurised. Sensors are delivered separately. The brake caliper shall be delivered as standard with a clamping gap of approx. 7.0 mm between the friction blocks.

### 6. Handling and storage

The technical data of the brake such as air pressure, clamping force, air volume, dimensions and weight are shown on the catalogue pages of the brake. The current data can also be found on the RINGSPANN website [www.ringspann.com](http://www.ringspann.com).

The brake can be stored for 12 months in an enclosed and dry place. It is to be made sure that no condensation develops. Damp storage rooms are not suitable. If storing the brake for a period longer than 12 months, as well as after any transport, the brake must be activated once in order to prevent the seals from getting stuck down.

<b>RINGSPANN</b>	<b>Installation and operating instructions for Brake DH 005 PFK pneumatically activated - spring released</b>			<b>E 09.638e</b>	
Issue: 27.07.2017	Version: 1	Signed.: BAHS	Checked: EISF	Pages: 11	Page: 7

## 7. Technical prerequisite for reliable operation

Fastening the brake to stable and low-vibration machine parts will ensure quiet braking without creaking.

## 8. Installing the RINGSPANN brake

### 8.1 General instructions regarding assembly and installation

Before installing the brake, the brake disc must be cleaned with alcohol (e.g. spirit (ethanol) or isopropyl alcohol) or with water-based tenside solutions (soapy water or the like).

If cleaning the brake disc with a diluent, acetone or brake cleaning agent, it must be ensured that these agents and no residues of these agents come into direct contact with the brake pads. This must be ensured for pure holding brakes in particular, since no dynamic braking takes place that would remove any diluent residues from the brake disc.



#### **Important!**

Residues from oil and anti-rust agent considerably reduce the coefficient of friction and thus also the braking and holding torque!

### 8.2 Assembly description

The standard brake callipers are fastened to the machine part with screws of strength class 8.8 or higher. (The screws are not included in the scope of supply. Please see the catalogue pages for quantities, sizes and lengths).

A quick coupling piece for air connection type CK-M5-PK-3 is situated on the brake caliper. The connection is carried out using a plastic hose type PU-3, PP-3 or PL-3 that has an inner diameter of 2.9 mm (or 3.0 mm) and an outer diameter of 4.3 (e.g. plastic hose PU-3, part no.: 5732, colour blue, by Festo AG, D-73734 Esslingen).

If the quick coupling piece needs to be exchanged, or if it is to be replaced by another design, the following must be observed:

The screw-in thread at the cylinder block is M5. The length of the cylindrical screw-in pin should be 5 mm. The screw-in pin simultaneously serves the centric alignment of the two pistons (item 4). Before screwing in the new screw connection, the pistons must be aligned precisely symmetrically in the cylinder block (item 1) so that the threaded pin of the hose screw connection protrudes into the designated installation space (determined by both pistons item 4).

For brake calipers of older types, both pistons (item 4) do not have any turned stop pins to hold the pistons at a distance for the threaded pin of the hose screw connection.

Here you may have to draw the two pistons to the required spacing before screwing in the new hose screw connection with a small screwdriver that you guide through the screw-in thread.

Compressed air is only to be applied after the brake caliper is mounted onto the brake disc.



**Caution - danger of injury!**

If compressed air activated during assembly, the brake can suddenly close!

Before assembly it is to be checked that the customer connection part is even and that the axial run-out between the brake disc and the mounting surface of the brake is within a tolerance of 0.3 mm.

Examine the axial movement of the brake disc. The axial movement must not be greater than  $\pm 0.3$  mm.

The maximum permissible lateral run-out of the brake disc is 0.1 mm. A greater lateral run-out can cause the brake unit to rattle and shake.

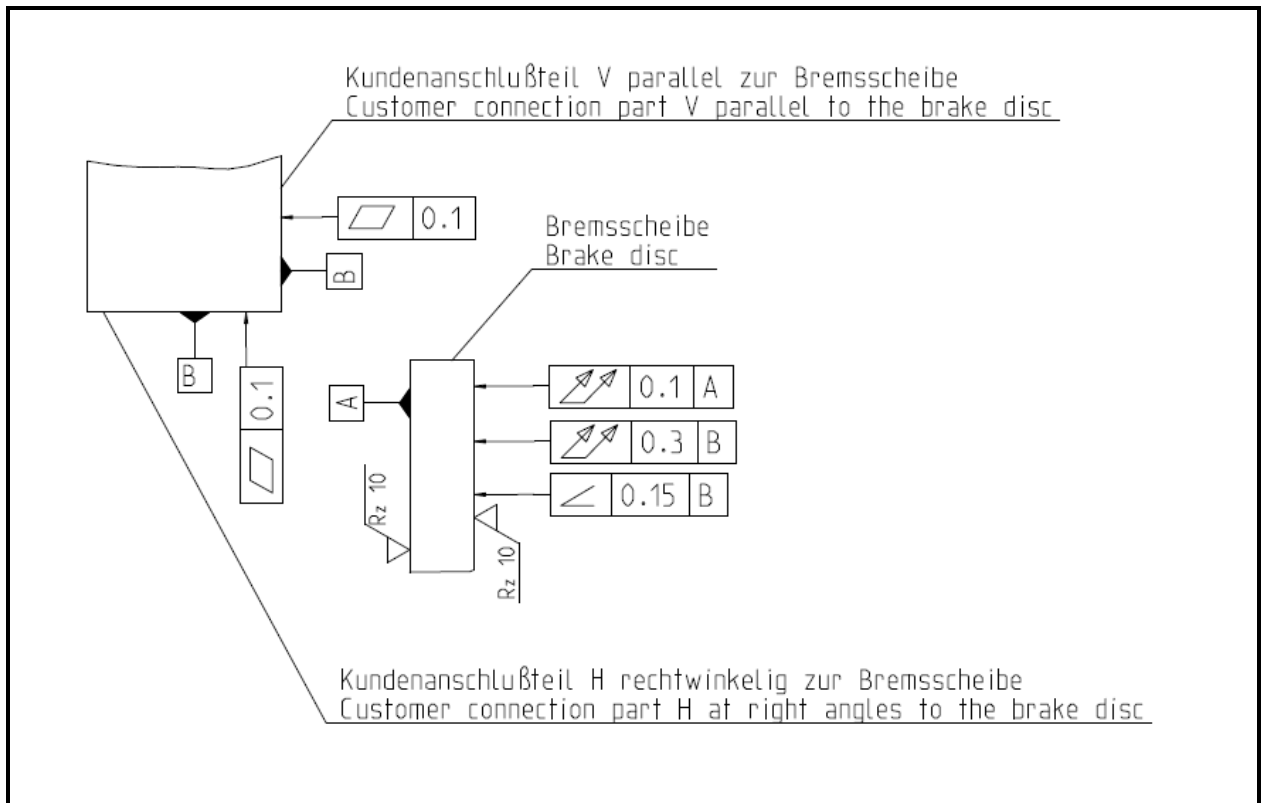

Fig. 8.1

The connecting plate for the brake as well as the brake disc must be checked for dimensional accuracy. For this purpose, the connection dimensions shown on the catalogue data sheet or installation drawing are to be checked.





**Important!**

Check whether the brake disc can be freely rotated.

### 8.3 Adjusting/readjusting the friction pad distance

Only wear inspection possible:

With lining wear on the friction linings, the levers (item 2) are widened further in the closed condition of the brake caliper (compressed air is applied to the brake caliper) see figure 2.1, measurement a.

Check, therefore, in regular intervals how far the levers (item 2) are widened with a closed brake caliper. Both friction blocks need to be exchanged at the latest when the width has reached a value of  $a = 78.0 \text{ mm}$ .

### 8.4 Connecting the signal cable (optional)

Attach the signal cable (e.g. via a signal lamp) to a 24V control voltage.

If the maximum friction lining abrasion limit is reached, contact with the neutral conductor will be made and the signal lamp will light up.

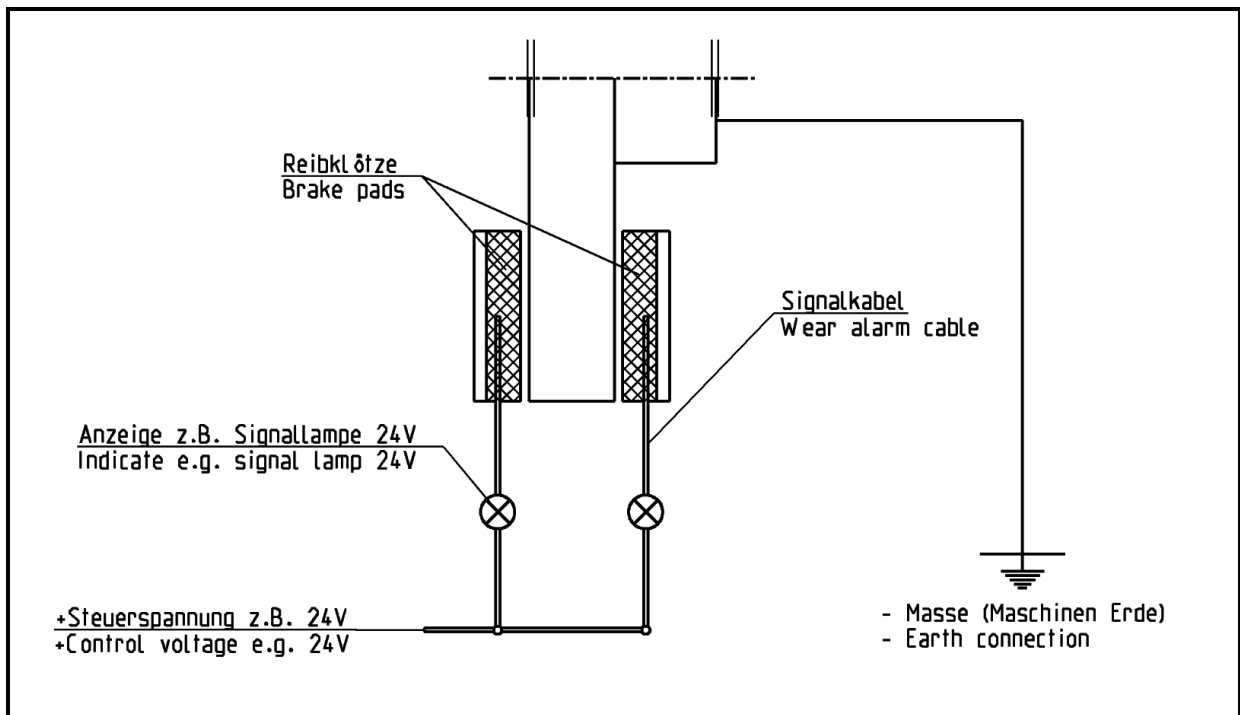

Fig. 8.2

## 9. Start-up

Only full-face contact of the two friction pads (item 1) on the brake disc as well as a rapid heating of the friction linings to approx.  $200^{\circ}\text{C}$  will ensure an optimal braking effect. It is therefore necessary to brake several times and for a short duration when the brake disc is rotating.

<b>RINGSPANN</b>	<b>Installation and operating instructions for Brake DH 005 PFK pneumatically activated - spring released</b>			<b>E 09.638e</b>	
Issue: 27.07.2017	Version: 1	Signed.: BAHS	Checked: EISF	Pages: 11	Page: 10



### Important!

If the brakes are used as holding brakes, then the braking torques indicated in the catalogue will not be reached. Reductions of up to 50% are possible if the brake will use as a parking brake.

## 10. Disassembling the brake



### Life-threatening danger!

**When disassembling the brake it is to be ensured that the entire drive train is secured against being switched on unintentionally. Rotating parts can cause severe injury. Rotating parts (e.g. brake disc) must be secured by the operator against unintentional touching.**

Remove the screws that serve for fastening the brake to the machine frame. The brake calliper can now be removed from the mounting surface.

## 11. Maintenance

### 11.1 General maintenance

Depending on how much the brake is used in operation, maintenance is to be carried out on it at intervals of 4 to 12 weeks.

The following is to be carried out when performing maintenance:

- Check the friction pads for wear.
- Check in released status. The friction pads do not grind on the brake disc and that there is an even air gap on both sides.
- Check the screw connection of the brake calliper and the screw connection of the friction blocks for firmness.
- Check both brake calliper levers for ease of movement.
- Clean the bearing and sliding points.
- Oil or grease the bearing and sliding points.
- Check the thruster and hose connection for tightness.



### Important!

The friction linings must not come into contact with the lubricant!

<b>RINGSPANN</b>	<b>Installation and operating instructions for Brake DH 005 PFK pneumatically activated - spring released</b>			<b>E 09.638e</b>	
Issue: 27.07.2017	Version: 1	Signed.: BAHS	Checked: EISF	Pages: 11	Page: 11

## 11.2 Permissible friction lining wear and exchanging of the friction pad



### **Life-threatening danger!**

Friction pads may only be changed when the system or the work machine is stationary!



### **Important!**

If the friction pads has 3,5mm wear out, the friction pads has to be change. The friction pads always change in pairs.

Only original RINGSPANN friction pads may be used.

Remove the splint (item 12), set the disc (item 13) to one side and pull the bolt (item11) out of the friction block and lever and remove the worn friction block (item5).

Press the new friction block with the rounded side against the return springs (item 3) and slide the bolt through the boreholes in the lever and friction block, install the disc (item 13) and secure the bolt using the splint (item12). Repeat the procedure on the opposite lever.

Before exchanging the friction pads, ensure that the mass held by the brake is secured against moving, since parts of the brake need to be loosened for this purpose.

## 11.3 Exchanging seals, wipers and piston seals

In case of sealing issues, the brake caliper blows off air, we recommend examining and having the brake caliper repaired by RINGSPANN. If this is not possible, proceed as follows:

- Screw off the brake caliper from the machine part.
- Lift the return spring (6) out of the spring bolts (9).
- Disassemble both brake levers (2) by removing the gripping rings (14) and pull out the bolts (10).
- Remove the hose screw connection (8).
- Now push out the piston (4) with the piston seals (7) out of the cylinder block (1).
- Disassemble the piston seals (7).
- Carefully clean all individual parts, particularly the seal ring slots and the cylinder borehole for the pistons (4).
- Mount the new piston seals (7) and coat prior to re-assembly thinly with ALVANIA grease G2 (Shell), and do the same to the cylinder borehole for the piston (4).
- Then screw the hose screw connection (8) into the cylinder block (1).
- Subsequently push the pistons (4) incl. the piston seals (7) into the cylinder borehole of the cylinder block (1).
- Re-assemble both brake levers (2). First coat the two bolts (10) thinly with ALVANIA grease G2. Secure the bolt using a gripping ring (14).
- Finally, re-insert the return spring (6).